

Service manual

B1.35_{MKII}

Powered Subwoofer
featuring B5 amplifier

ace-bass
TECHNOLOGY

World patents:
Australia 508491
Great Britain 1565858
Canada 1083490
Sweden 7603585.6
USA 4.118.600



audio pro

Audio Pro AB. Box 1015. S-251 10 HELSINGBORG
SWEDEN

audio pro

audio pro

Important note when repairing power amp pcb on B.5 or B.6 amp's.

Before you perform soldering / unsoldering or DC resistance measuring on power amp pcb, connector CN03B must be disconnected. Otherwise unwanted discharge might cause damage on semiconductors.

Technical data B1.35MkII

Enclosure:	150W powered, bass reflex.
Drive units, Woofer:	10" heavy duty woofer
Crossover -Hi Pass:	100Hz
-Lo Pass:	50 - 100Hz
Freq.range:	25-100Hz
Power requirements:	AC 230V 50HZ
Power consumption (max):	200W
Dimensions(WxHxD mm):	350x380x350

Adjustment of negative output resistance in B1.35 MkII amplifier

Set jumper "Set 1" on power amp pcb in Trim position.

Connect a signal generator to input and an AC voltmeter to speaker output.

Set level and frequency controls to maximum (fully clockwise) and switch amplifier on.

Set signal generator to 50 Hz and adjust level until AC voltmeter on speaker output reads 1.00 V under no load condition.

Connect a resistor 4.00 Ohm (1%, 5W) to speaker output.

Adjust trim-potentiometer VR 202 until AC voltmeter reads 3.00V.

Switch amplifier off and set jumper in Run position.

Important note!

This is an amplifier using ACE Bass technique. It can only be used with the driver to which the specific ACE Bass circuit is designed.

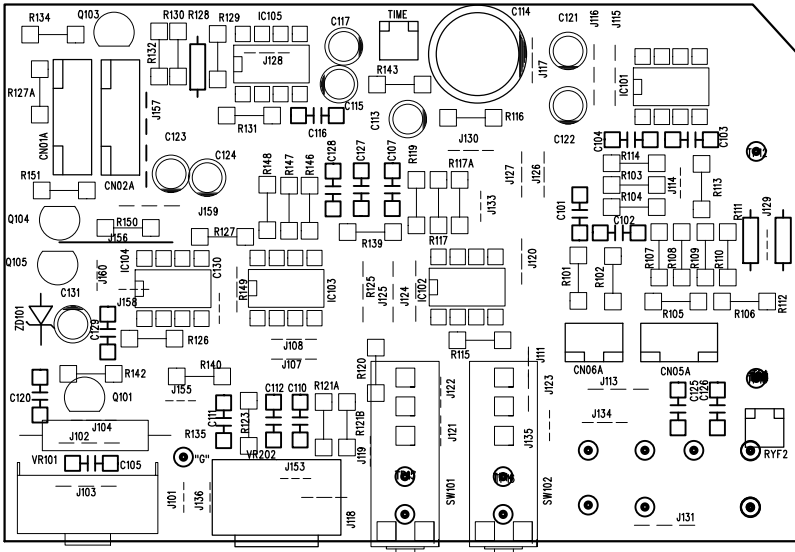

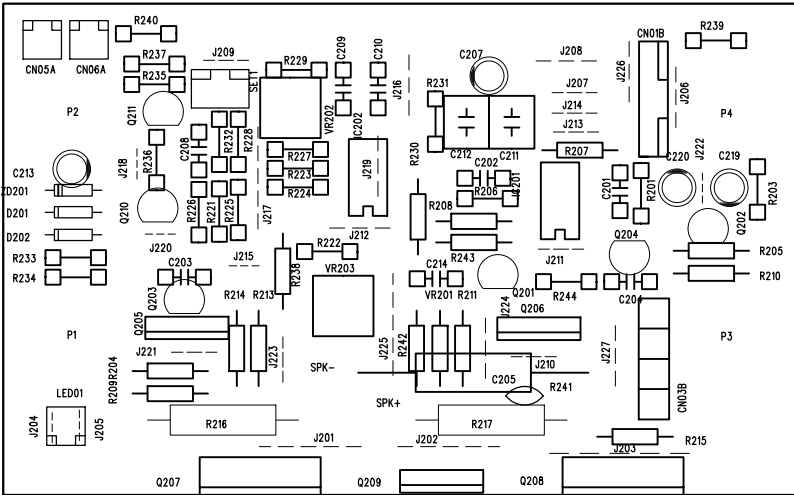

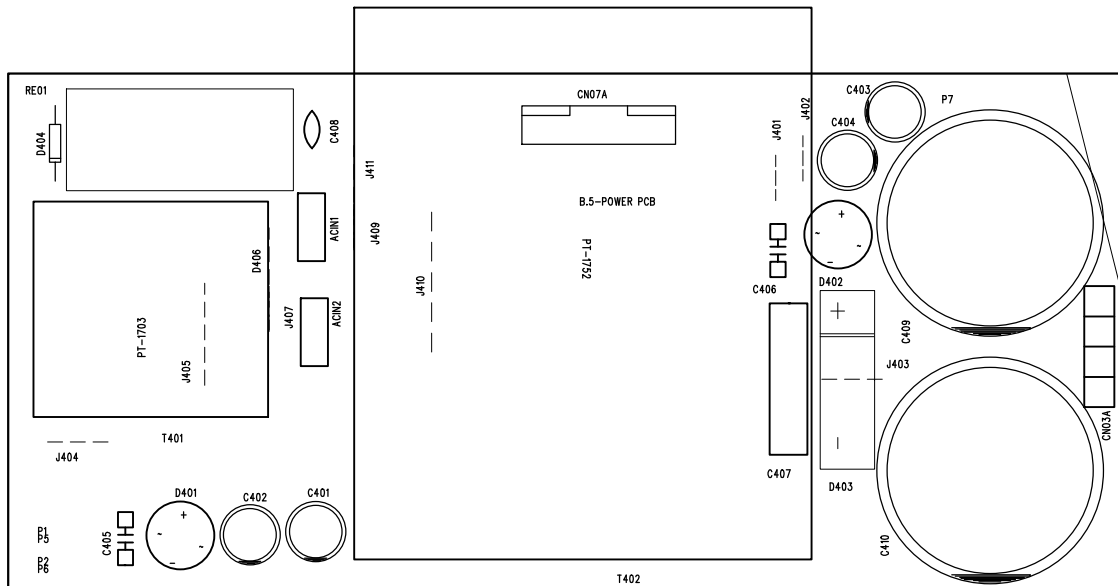

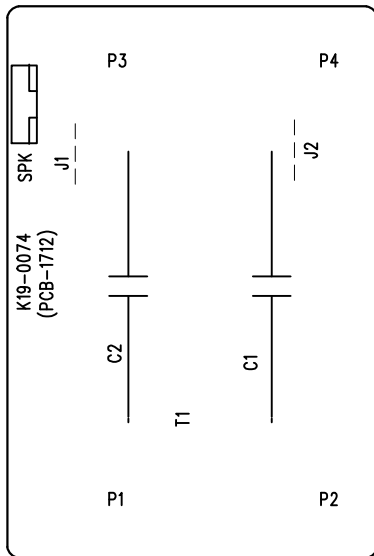

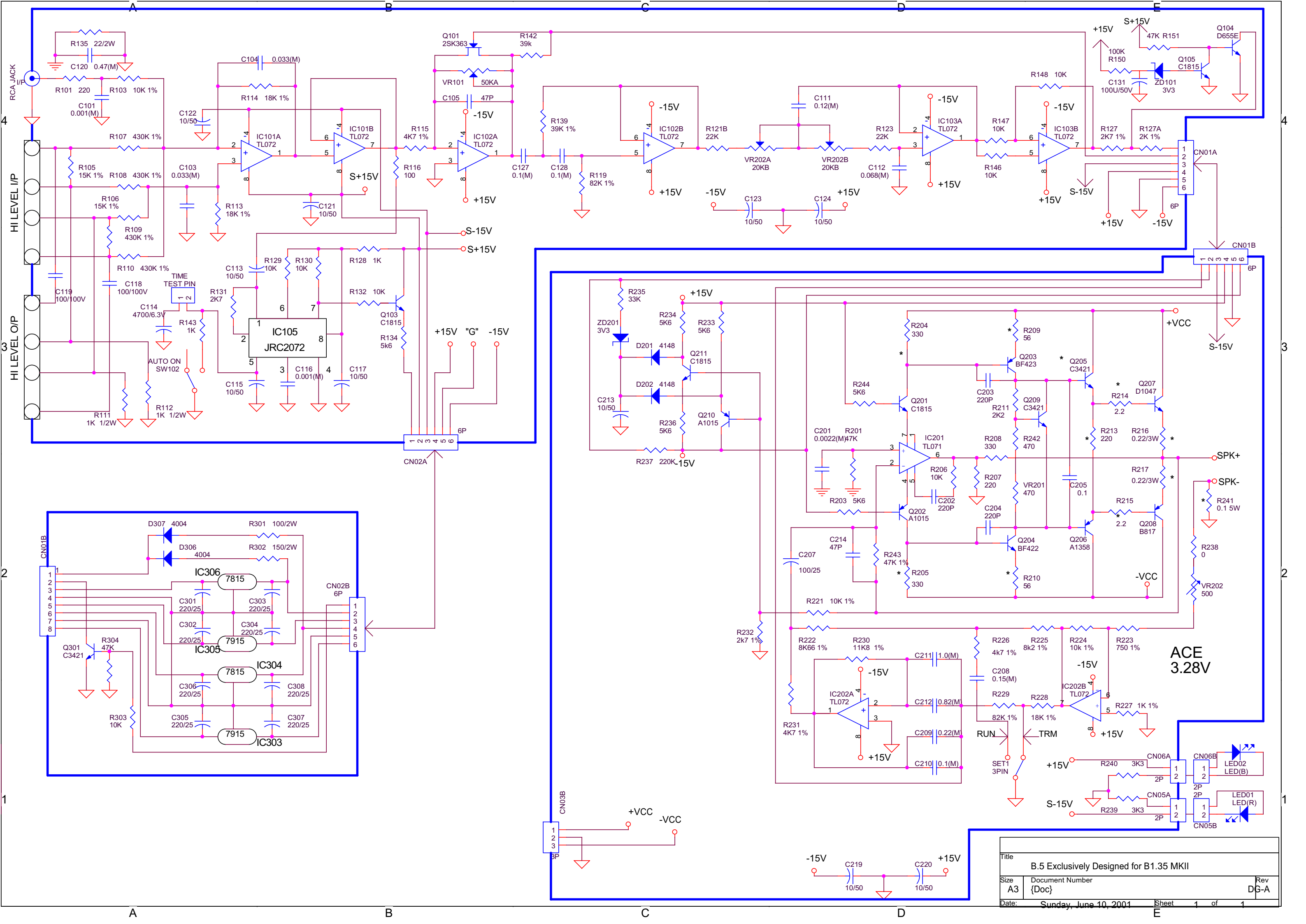

Title		
B.5 Exclusively Designed for B1.35 MKII		
Size	Document Number	Rev
A3	{Doc}	DG-A
Date:	Sunday, June 10, 2001	Sheet 1 of 1

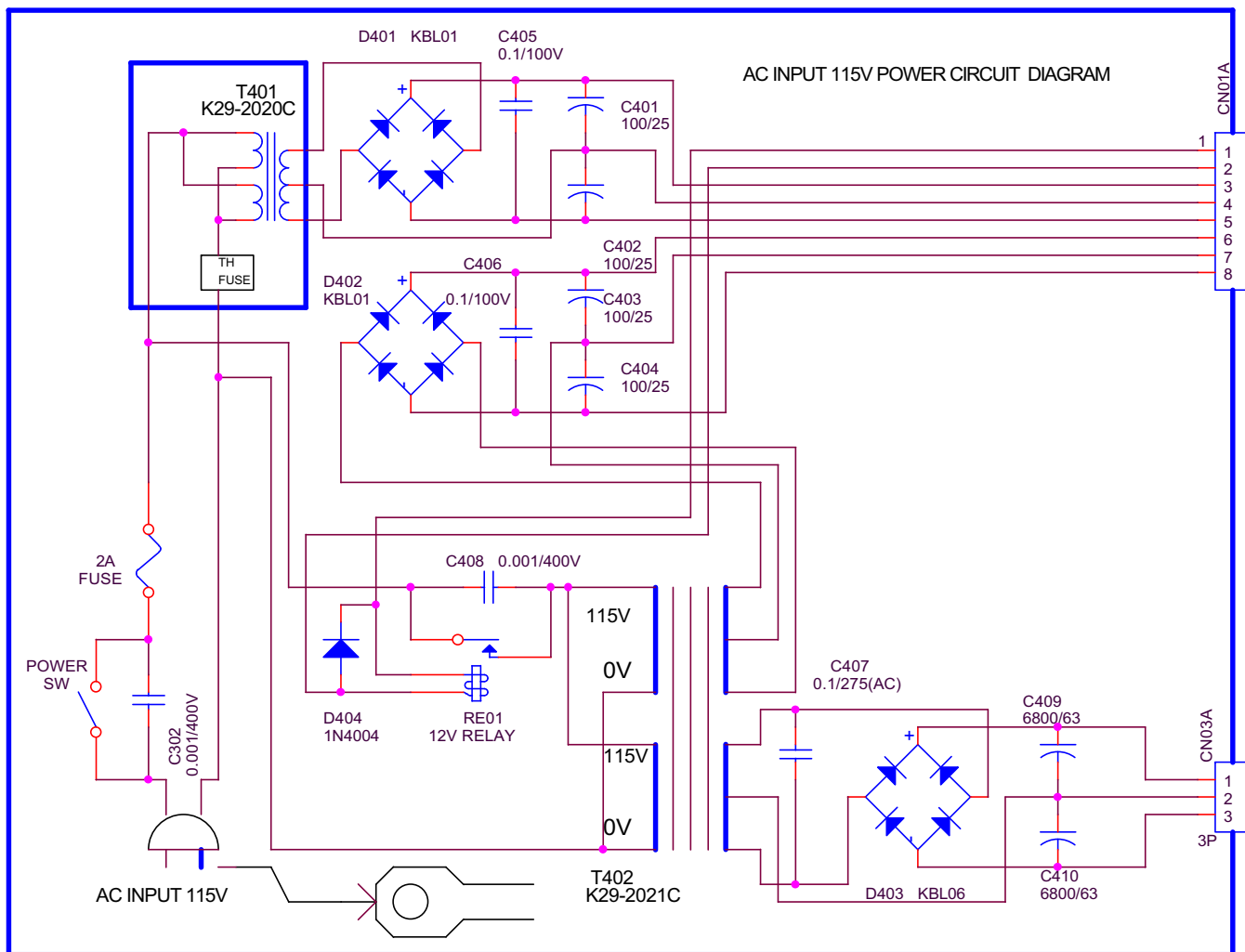
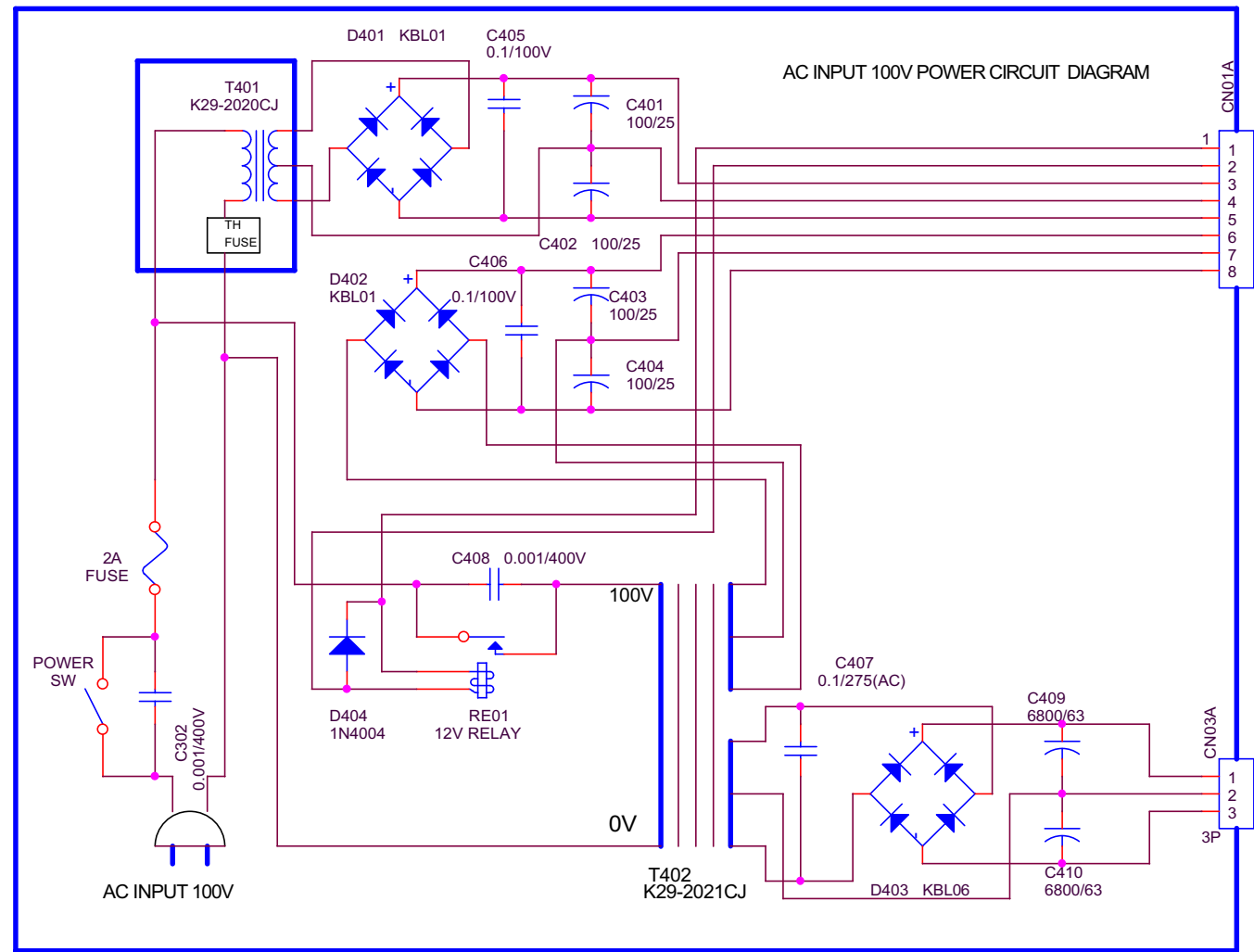
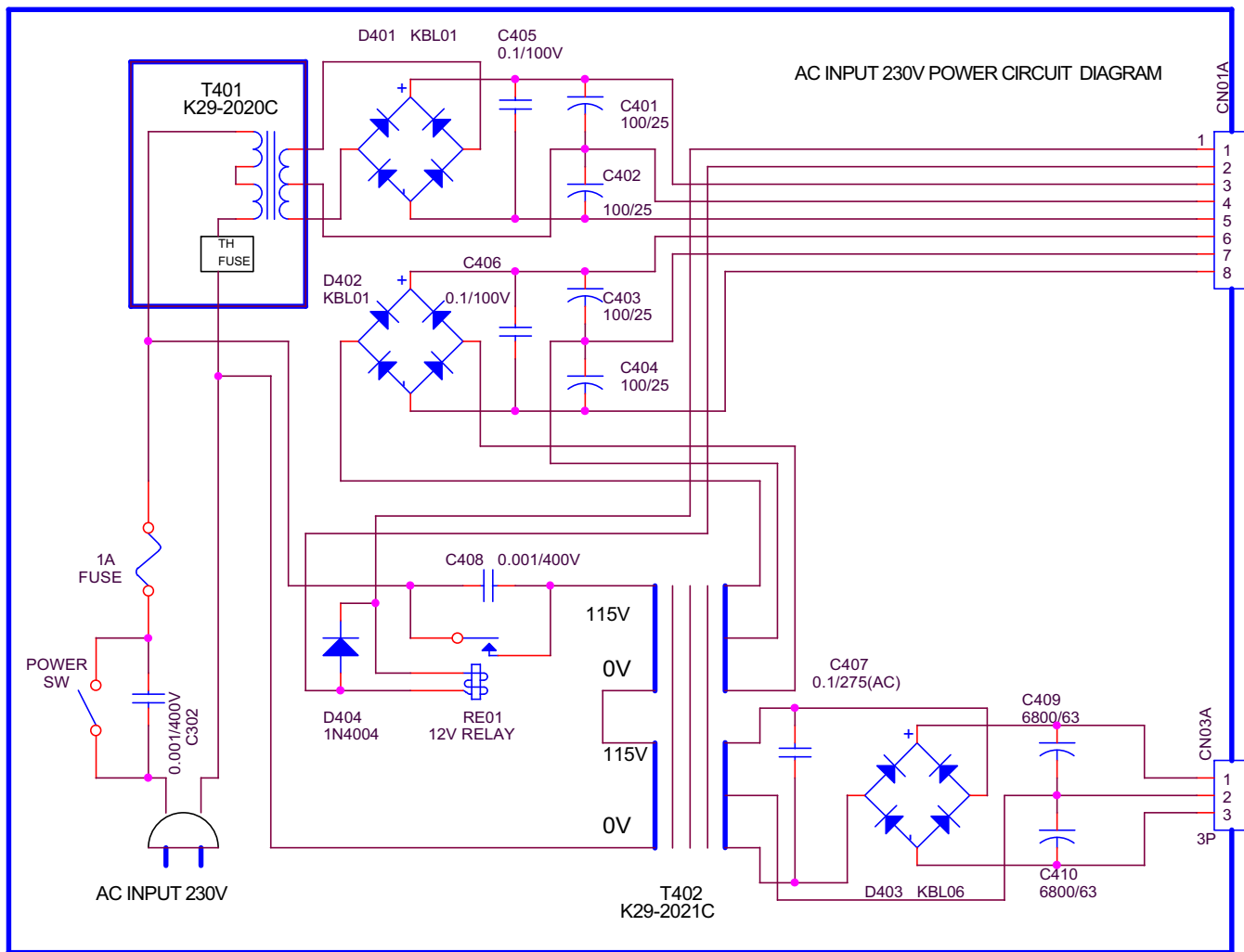

This page shows the different circuit for the different AC line voltage.

Title		
B5 Exclusively Designed for B1.35 MKII		
Size	Document Number	Rev
A3	{Doc}	DG-A
Date:	Wednesday, June 06, 2001	Sheet 1 of 1

<u>Parts list B1.35MkII (B5) 230V/50Hz</u>			
PART NUMBER	DESCRIPTION	SPECIFICATION	REMARK
ASSY AMP			
ATR-2SB817E	TR	2SB817E (A1492)	Q208
ATR-2SC3421	TR	2SC3421	Q209
ATR-2SD1047E	TR	2SD1047E (C3856)	Q207
M11-P605-02	VR-KNOB	18*16	FOR VR
WPC-7007	POWER CORD	6FT VDE (AL-104)	BAK PANEL
EMX-7005	AC CORD BUSHER	ST-100N HEYCO	BAK PANEL
FUH-1006	FUSE HOLDER 5*20MM	VDE/UL OP520	PANEL
FUS-01-1001SC	FUSE VDE/UL	5*20 1A/250V TSD	FUSE HOLDER
SWK-7009	SWROCK R-30NS	RH SERIAL	BAK PANEL
VRR-7045	VR B20K R1610G-2A1-B20K		VR202
VRR-G7006	VR 50K R1610N-2A7-A50K		VR101
XFM-3013	XFORMER(K29-2021C)	AC 28.0*2 FOR B.5	T402
ECW-400V102K	CAP Y-SUPPRESSOR	0.001UF/400V +-10%	POWER -SW
ADL-6S702	LED	RED 5MMD	LED01
EMX-1018	LED BUSHING	5MM	BLU LED
WAS-7368	WIRE ASS'Y 1P RCA	PLUG*2 6M BAK	RCA CABLE
ADL-6S701	LED BLUE	5MMD	CONNECTED WITH WAS-7472B
IN/OUT BOARD SP			
ECJ-100A107K	CAP ELNP	100V 100UF +-10%(A TYPE)	SPK, LEVEL
TML-7021	TERMINAL SPEAKER	CJ-9011-07-0200A	1,2--7,8

<u>Parts list B1.35MkII (B5) 230V/50Hz</u>			
PART NUMBER	DESCRIPTION	SPECIFICATION	REMARK
INPUT PCB			
ERB-202K220J	RES MO 2W K 22 +-5%	H=10mm 5.0*16.0	R135
ERB-501Y102J	RES MO	1/2W Y 1K +-5%	R111,R112
ECZ-063T474J-1	CAP MTLZ (BF014D)	63V 0.47uF +-5%	C120
ECE-050T106M-1	CAP ELE	50V 10uF +-20%	C115,C117,C113,C121-124
ECE-0063V478M-A1	CAP ELE 6.3V	4700uF +-20% JUNFU	C114
ECE-050T107M-1	CAP ELE	50V 100uF +-20%	C131
ECD-050T470M	CAP CER	50V 47P +-20%	C105
ECM-100T102J	CAP MYLAR	100V 0.001uF +-5%	C101,C116
ECM-100T333J	CAP MYLAR	100V 0.033UF +-5%	C104,C103
ECM-100T104J	CAP, MYLAR	100NF 100V +/-5% P5	C127,C128
ECM-100T124J	CAP MYLAR	100V 0.12UF +-5%	C111
ECM-100T683J	CAP, MYLAR	68NF 100V +/-5% P5	C112
ERM-121Y1002F	RES MF	1/8W Y 10K +-1%	R103
ERM-121Y4303F	RES MF	1/8W Y 430K +-1%	R107-R110
ERM-121Y1502F	RES MF	1/8W Y 15K +-1%	R105,R106
ERM-121Y1802F	RES MF	1/8W Y 18K +-1%	R113,R114
ERM-121Y4701F	RES MF	1/8W Y 4K7 +-1%	R115
ERM-121Y3902F	RES MF	1/8W Y 39K +-1%	R139
ERM-121Y8202F	RES MF	1/8W Y 82K +-1%	R119
ERM-121Y2701F	RES MF	1/8W Y 2K7 +-1%	R127
ERM-121Y2001F	RES MF	1/8W Y 2K +-1%	R127A
ERC-121Y393J	RES, 39K OHM	1/6W +/-5%	R142
ERC-121Y221J	RES CF	1/8W Y 220 +-5%	R101
ERC-121Y272J	RES, 2K7 OHM	1/6W +/-5%	R131
ERC-121Y473J	RES, 47K OHM	1/6W +/-5%	R151
ERC-121Y103J	RES, 10K OHM	1/6W +/-5%	R129,130,132,146,147,148
ERC-121Y104J	RES, 100K OHM	1/6W +/-5%	R150
ERC-121Y101J	RES CF 1/8W Y	100 +-5%	R116
ERC-121Y102J	RES, 1K0 OHM	1/6W +/-5%	R143
ERC-121Y562J	RES CF	1/8W Y 5K6 +-5%	R134
ERC-121Y223J	RES, 22K OHM	1/6W +/-5%	R123,R121B
ERC-251Y102J	RES, 1K0 OHM	1/4W +-5%	R128
CN1-S25402-702	SHORT PIN 2P		2P NEEDLE
CN1-S25402-703	2P NEEDLE		TIME
ATR-2SC1815*TAP	TR	2SC1815	Q103,Q105

<u>Parts list B1.35MkII (B5) 230V/50Hz</u>			
PART NUMBER	DESCRIPTION	SPECIFICATION	REMARK
ATR-2SK363	TR	2SK363	Q101
ATR-2SD655E	TR	2SD655E	Q104
AIC-TL072	IC DVAL OP AMP	TL072	IC101,102,103
AIC-NJM2072D	IC	SIGNAL SENSOR NJM2072D	IC105
ADZ-UZ3.3BM	DIODE ZENER UZ	3.3BM 1/2W	ZD101
SWS-G7002	TOGGLE SW	T8019L-TECQ	SW102
JK3-L01-709	RCA JACK	1P (RCA-081) SILVERED	1P RCA JACK
POWER AMP PCB			
ADZ-UZ3.3BM	DIODE ZENER UZ	3.3BM 1/2W	ZD201
ADD-IN4148*TAP	DIODE SWITCH	IN4148 52mm	D201,D202
ECE-025T107M-1	CAP ELE	25V 100uF +-20%	C207
ECE-050T106M-1	CAP ELE	50V 10uF +-20%	C219,C220,C213
ERC-121Y333J	RES, 33K OHM	1/6W +/-5%	R235
ERC-121Y473J	RES, 47K OHM	1/6W +/-5%	R201
ERC-121Y562J	RES CF	1/8W Y 5K6 +-5%	R233,R234,R236,R203,R244
ERC-121Y224J	RES CF	1/8W Y 220K +-5%	R237
ERC-121Y332J	RES CF	1/8W Y 3K3 +-5%	R239,R240
ERC-121Y103J	RES, 10K OHM	1/6W +/-5%	R206
ERC-251Y331J	RES CF	1/4W Y 330 +-5%	R208
ERC-251Y221J	RES 220 OHM	1/4W Y +-5%	R207
ERC-251Y471J	RES CF	1/4W Y 470 +-5%	VR201,R242
ERC-251Y222J	RES, 2K2 OHM	1/4W +-5%	R211
ECD-050T221M	CAP, CER	220P 50V +-20% P5	C202,C203,C204
ECD-050T222M	CAP CER	50V 0.0022uF +-20%	C201

<u>Parts list B1.35MkII (B5) 230V/50Hz</u>			
PART NUMBER	DESCRIPTION	SPECIFICATION	REMARK
ECD-050T470M	CAP CER	50V 47P +-20%	C214
ECD-100T104M	CAP CER	100V 0.1UF +-20%	C205
ERB-251Y221J	RES MO	1/4W Y 220 +-5%	R213
ERB-251Y331J	RES MO	1/4W Y 330 +-5%	R204,R205
ERB-251Y560J	RES MO	1/4W Y 56 +-5%	R209,R210
ERB-251Y2R2J	RES MO	1/4W Y 2.2 +-5%	R214,R215
ERB-302KR22J	RES MO 3W K 0.22 +-5%	H=10mm 6.5*17.5	R216,R217
ERD-502K0R1J	RES FR	5W K 0.1 +-5%	R241
ERV-S06-501B01	VR SEMI ST S	6MMD 500V	VR202
CN1-S25403-702	3P NEEDLE		SET1
CN1-S25402-702	SHORT PIN 2P		3P NEEDLE
ERM-251Y4702F	RES MF	1/4W Y 47K +-1%	R243
ERM-121Y1001F	RES MF	1/8W Y 1K +-1%	R227
ERM-121Y1002F	RES MF	1/8W Y 10K +-1%	R224,R221
ERM-121Y1802F	RES MF	1/8W Y 18K +-1%	R228
ERM-121Y2701F	RES MF	1/8W Y 2K7 +-1%	R232
ERM-121Y7500F	RES MF	1/8W Y 750 +-1%	R223
ERM-121Y4701F	RES MF	1/8W Y 4K7 +-1%	R231,R226
ERM-121Y8201F	RES MF	1/8W Y 8K2 +-1%	R225
ERM-121Y8661F	RES MF	1/8W Y 8K66 +-1%	R222
ERM-121Y8202F	RES MF	1/8W Y 82K +-1%	R229
ERM-251Y1182F	RES MF	1/4W 11.8K +-1%	R230
ECZ-063T104J-1	CAP MTLZ (BF014D)	63V 0.1uF +-5%	C210
ECZ-063T105J-1	CAP MTLZ (BF074D)	63V 1uF +-5%	C211
ECZ-063T154J-1	CAP MTLZ (BF014D)	63V 0.15uF +-5%	C208
ECZ-063T224J-1	CAP MTLZ (BF014D)	63V 0.22uF +-5%	C209
ECZ-063T824J-1	CAP MTLZ (BF014D)	63V 0.82uF +-5%	C212
ATR-2SC1815*TAP	TR	2SC1815	Q211,Q201
ATR-2SA1015*TAP	TR	2SA1015	Q210,Q202
ATR-BF422	TR	BF422 TAPING	Q204
ATR-BF423	TR	BF423 TAPING	Q203
ATR-2SA1358	TR	2SA1358	Q206
ATR-2SC3421	TR	2SC3421	Q205
AIC-TL071	IC	TL071(TI)	IC201
AIC-TL072	IC DVAL OP AMP	TL072	IC202

<u>Parts list B1.35MkII (B5) 230V/50Hz</u>			
PART NUMBER	DESCRIPTION	SPECIFICATION	REMARK
15V POWER SUPPLY PCB			
ATR-2SC3421	TR	2SC3421	Q301
ADD-IN4004*TAP52	DIODE RECTI	IN4004 TAPING 52mm	D306,D307
AIC-KA7815	IC KA	7815	IC304,IC306
AIC-KA7915F	IC KA	7915	IC303, IC305
ECE-025T227M-1	CAP ELE	25V 220uF +- 20%	C301-308
ERC-121Y473J	RES, 47K OHM	1/6W +/-5%	R304
ERC-121Y103J	RES, 10K OHM	1/6W +/-5%	R303
ERB-202K101J	RES MO 2WK 100 +-5%	H=10mm 5.0*16.0	R301
ERB-202K151J	RES MO 2W K 150 +-5%	H=10mm 5.0*16.0	R302
POWER SUPPLY PCB			
ADB-KBU6G	DIODE BRIDGE KBU6G	6A/400V	D403
ADB-W02	DIODE BRIDGE	W02 1.5A/200V	D401,D402
ADD-IN4004*TAP52	DIODE RECTI	IN4004 TAPING 52mm	D404
ARL-01-7002	RELAY 12V 1P1T	MIT-SH-112LM	RE01
ECE-025T107M-1	CAP ELE	25V 100uF +-20%	C401-404
ECE-063V688M-2	CAP ELE	63V 6800uF+-20%	C409,C410
ECD-100T104M	CAP CER	100V 0.1UF +-20%	C406,C405
ECW-275V104K	X-CAP 14104	0.1uF/275V	C407
ECW-400V102K	CAP Y-SUPPRESSOR	0.001UF/400V +-10%	C408
XFM-3012	XFORMER (K29-2020C)	AC 15.0V*2	T401